

HDigit

EN DE

FR IT

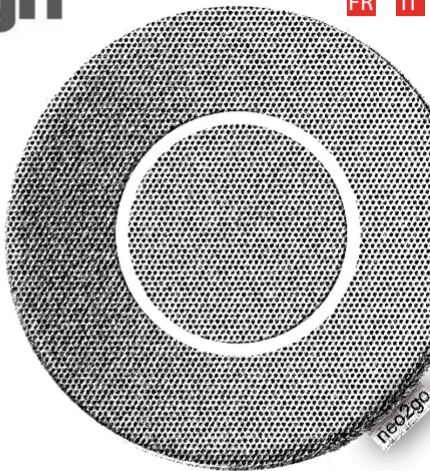

Bluetooth



Water Resistant



Suction Cup



Interphone

neo2go water resistant wireless speaker

neo2go water resistant wireless speaker

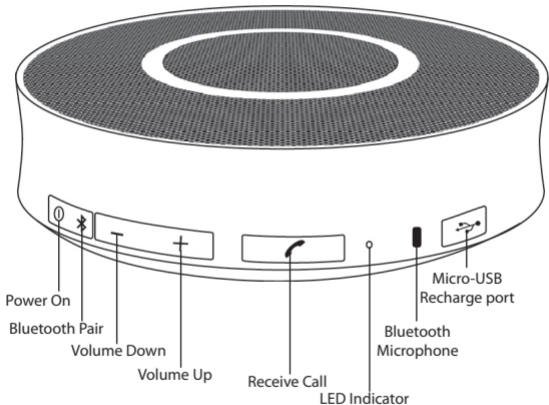



The core value of the **neo2go** is the patented acoustic design, employing a smaller size to produce a better sound performance.



Bluetooth V2.1 + EDR(A2DP)

Maximum cordless distance 10 meters

Battery life: up to 12 hours (Lithium battery 1000mAh)

Power: 2.0W T.H.D. <1%

Size: Ø100*32H(mm)

Weight: 132g

neo2go water resistant wireless speaker





neo2go is designed to enrich the experience of the smart phone users.

More than 100 million smartphones with Bluetooth are on the market, and **neo2go** is designed for these potential customers to help them enjoy the quality music almost anywhere without their headphones.







Connect with SmartPhone and other bluetooth devices.

1. Switch **neo2go**   ON , LED button shows blue, then blink between blue and red while searching
2. Bluetooth will auto-search for the last previously paired units (for up to 10 seconds).
3. Once paired, the front LED button will continue to flash blue.
4. If Bluetooth can't discover prior paired units, it will search for new units to pair with.
5. Start your Bluetooth device and search for **neo2go**. The Bluetooth ID "**neo2go**" will be detected in your Bluetooth manager. Once located, select to pair and connect with **neo2go**.
6. If Bluetooth can't pair successful (about 2 and half minutes), it will auto turn off. Follow your device's instructions for Bluetooth Pairing. (Each is different!) Initial pairing code is 0000.
Some take just seconds to pair, and some are less friendly and can take longer.
7. **neo2go** can pair with 2 bluetooth devices at the same time. : When one devices pairing, tap the pairing(power)   button till the indicator LED blink between blue & red, then your second Bluetooth device can detect **neo2go** again (just repeat step 5) .

Then, Enjoy the music by wireless.

Adjust the sound and volume

Adjust the +/- volume   to your preferred volume level .The beep will remind at the maximum level.

neo2go water resistant wireless speaker

Turn Off: Press and hold the Power/Pair button until the LED turns OFF (about 5 seconds)
The speaker will automatically turn off after 10 minutes if not connected to a device.

Call Function

1. Answer or end a call: 

Tap the Phone button <1.5 seconds to answer or end a call.

2. Reject incoming call: 

Push and hold the phone button >1.5 seconds.

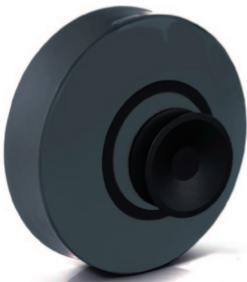

The double faced suction cup is the most interesting feature of **neo2go**.

Thanks to this smart design, the speaker can be easily attached to any flat surface such as tiles, mirrors and windows etc.

HDigit

EN DE

FR IT

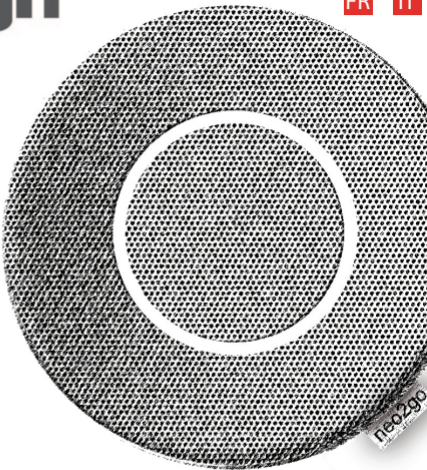

Bluetooth



Water
Resistant



Suction Cup



Interphone

neo2go Wasserfester Funklautsprecher

neo2go wasserfester funklautsprecher

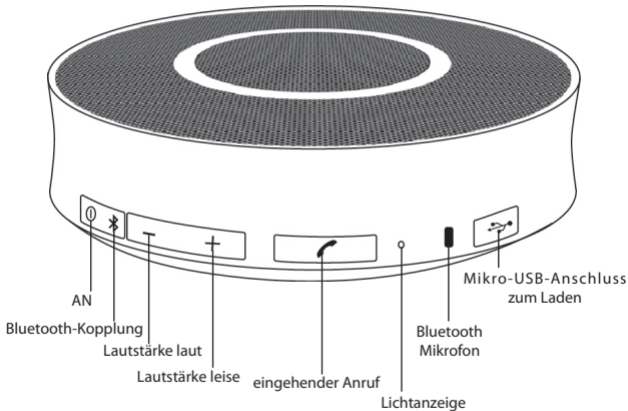

Die besondere Qualität von **neo2go** ist das patentierte Akustik-Design, das eine kleinere Größe für bessere Audio-Leistung verwendet



1. Aktiv-Lautsprecher-Driver
2. Passiver Radiator mit rundem Rand
3. Elastischer Träger

Bluetooth V2.1 + EDR (A2DP)

Maximale Reichweite: 10 Meter

Akkulaufzeit: bis zu 12 Stunden (Lithium-Batterie 1000mAh)

Power: 2.0W T.H.D. <1%

Größe: 100 x 32H (mm)



Gewicht: 132 g

neo2go wasserfester funklautsprecher

neo2go wurde entwickelt, um die Erfahrung von Smartphone-Nutzer zu bereichern. Auf dem Markt gibt es mehr als 100 Millionen Smartphones mit Bluetooth und **neo2go** wurde für diese potenziellen Kunden erschaffen, um qualitativ hochwertige Musik fast überall ohne Kopfhörer genießen zu können.



Verbinden mit SmartPhones und anderen Bluetooth-Geräten

1. Schalten Sie ihr Gerät auf  ON , die LED-Taste leuchtet erst blau, blinkt dann während der Suche zwischen blau und rot
2. Bluetooth wird automatisch nach den zuvor gekoppelten Einheiten suchen (bis zu 10 Sekunden).
3. Einmal angemeldet, wird die vordere LED-Taste weiter blau blinken
4. Wenn Bluetooth keine zuvor gepaarten Einheiten finden kann, wird es nach neuen suchen.
5. Starten Sie Ihr Bluetooth-Gerät und suchen Sie nach **neo2go**. Ihr Bluetooth Manager wird die ID "neo2go" finden. Wählen Sie diese um zu koppeln und mit **neo2go** verbunden zu werden.
6. Sollte Bluetooth nicht in der Lage sein, die Kopplung durchzuführen (etwa 2 ½ Minuten) wird es sich automatisch ausschalten. Folgen Sie den Anweisungen Ihres Gerätes zur Bluetooth Kopplung. (Jedes ist anders!) Der Kopplungs-Code ist 0000. Manche brauchen nur wenige Sekunden zum Koppeln, bei anderen könnte es länger dauern.
7. **neo2go** kann mit 2 Bluetooth-Geräten gleichzeitig koppeln. Wenn Sie das erste Gerät koppeln tippen Sie auf die Pairing-Taste (Power)  bis die LED-Anzeige abwechselnd blau und rot blinkt, erst danach kann Ihr zweites Bluetooth-Gerät **neo2go** finden. Wiederholen Sie punkt 5) .

Genießen Sie Ihre Musik drahtlos
Klang und Volumen einstellen

Stellen Sie +/- das Volumen   auf Ihre bevorzugte Lautstärke ein.
Der Signalton wird Sie an die maximale Lautstärke erinnern

neo2go wasserfester funklautsprecher

Ausschalten: Drücken und halten Sie die Power / Paarungs-Taste bis das LED ausgeht. (ca. 5 Sekunden)

Der Lautsprecher schaltet sich automatisch nach 10 Minuten aus, wenn er mit keinem Gerät verbunden wird.

Anruffunktion:

1) Annehmen oder Beenden eines Anrufs 
tippen Sie auf die Telefon-Taste <1,5 Sekunden zum Annehmen oder Beenden eines Anrufs

2) eingehenden Anruf ablehnen 
drücken und halten Sie die Telefon-Taste >1,5 Sekunden

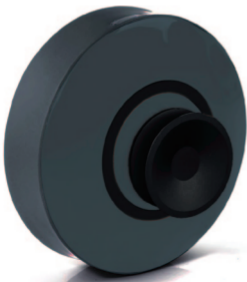

Der zweiseitige Saugnapf ist der interessanteste Trick von **neo2go**.

Dank dieser intelligenten Bauweise kann der Lautsprecher einfach auf jeder ebenen Fläche wie Fliesen, Spiegel, Fenster etc. angebracht werden .

HDigit

EN DE

FR IT

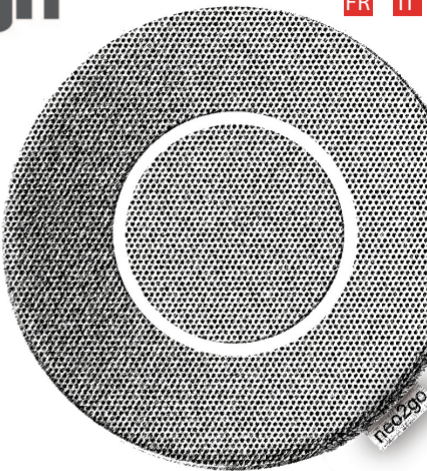

Bluetooth



Water
Resistant



Suction Cup



Interphone

neo2go haut-parleur wifi résistant à l'eau

neo2go haut-parleur wifi résistant à l'eau

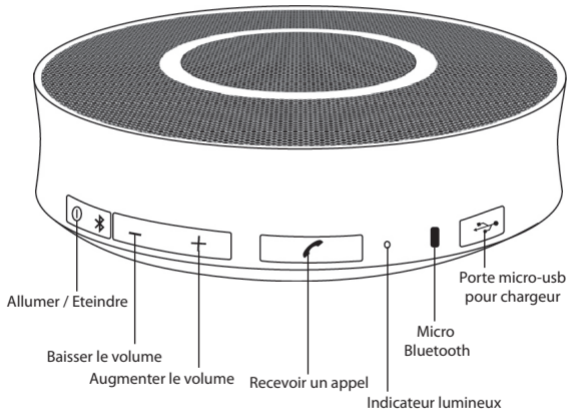

L'atout principale de **neo2go** est son design acoustique breveté, qui utilise un appareil de petite dimension pour produire une meilleure performance du son.

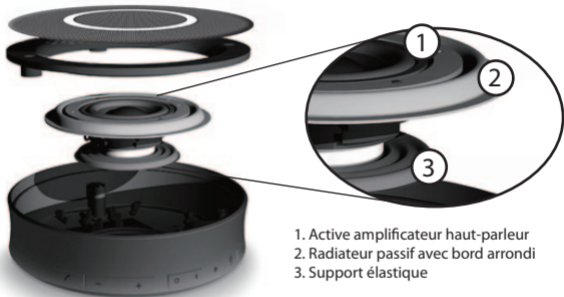

1. Active amplificateur haut-parleur
2. Radiateur passif avec bord arrondi
3. Support élastique

Bluetooth V2.1 + EDR (A2DP)

Distance maximum sans fil: 10 mètres

Durée batterie: jusqu'à 12 heures (batterie au lithium 1000mAh)

Puissance : 2.0ww T.H.D.<1%

Dimension : Ø100*32H (mm)

Poids : 132g





neo2go haut-parleur wifi résistant à l'eau

neo2go a été dessiné pour enrichir l'expérience des utilisateurs de Smartphone.

Il y a plus de 100 millions de Smartphones avec Bluetooth sur le marché et **neo2go** a été dessiné pour ces potentiels clients, pour les aider à apprécier la qualité de la musique presque partout sans l'aide d'écouteurs.



Se connecter avec un SmartPhone ou autres dispositifs bluetooth .

1. Allumez **neo2go**   le LED devient bleue, ensuite il clignote bleu et le rouge alternativement pendant la recherche
2. Le Bluetooth recherchera automatiquement les dernières unités jumelées (pendant 10 secondes).
3. Dès que le jumelage sera terminé, le LED continuera à flasher en bleu.
4. Si le Bluetooth ne trouve pas d'unités jumelées précédemment, il recherchera de nouvelles unités à jumeler.
5. Allumez votre dispositif Bluetooth et recherchez **neo2go**. Votre manager Bluetooth relevera l'ID Bluetooth "**neo2go**". Une fois localisé, sélectionner pour effectuer le jumelage et la connexion à **neo2go**.
6. Si le Bluetooth n'arrive pas à se jumeler (environs 2 minutes et demi), il s'éteindra automatiquement. Suivre les instructions de votre appareil pour le jumelage (chaque système est différent !) Le code initial de jumelage est 0000.
Certains appareils ont besoin de quelques secondes pour le jumelage, tandis que d'autres peuvent avoir besoin de plus de temps.
7. **neo2go** peut se jumeler avec 2 appareils Bluetooth en même temps : quand un des appareils a été jumelé, appuyer sur la touche jumelage jusqu'à ce   que le LED commence à clignoter bleu et le rouge alternativement ensuite votre deuxième appareil peut détecter à nouveau **neo2go**. Et simplement répétez la démarche 5) .

Ensuite, appréciez la musique en wifi.

Réglez le son et le volume

Réglez le volume   à votre niveau préféré. Un bip vous signalera le niveau maximum.

neo2go haut-parleur wifi résistant à l'eau

Eteindre : Appuyez et maintenir la touche power/pair jusqu'à ce que le LED s'éteigne. (environs 5 secondes)

Les haut-parleur s'éteindront automatiquement après 10 minutes si non connectés à un appareil.

Fonction appel

1. Répondre ou terminer un appel: 

Appuyez sur la touche PHONE <1,5 secondes, pour répondre ou terminer un appel

2. Refuser un appel en entrée : 

Appuyez et maintenir la touche PHONE >1,5 secondes

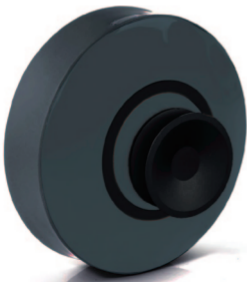

La ventouse double-face est l'astuce plus intéressante de **neo2go**.

Grâce à son design intelligent le haut-parleur peut facilement être placé sur n'importe quelle surface plate comme par exemple carreaux , miroirs, fenêtres, etc.

HDigit

EN DE

FR IT

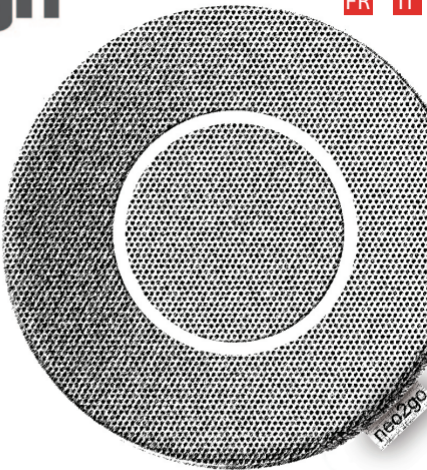

Bluetooth



Water
Resistant



Suction Cup



Interphone

neo2go altoparlante wireless resistente all'acqua

neo2go altoparlante wireless resistente all'acqua

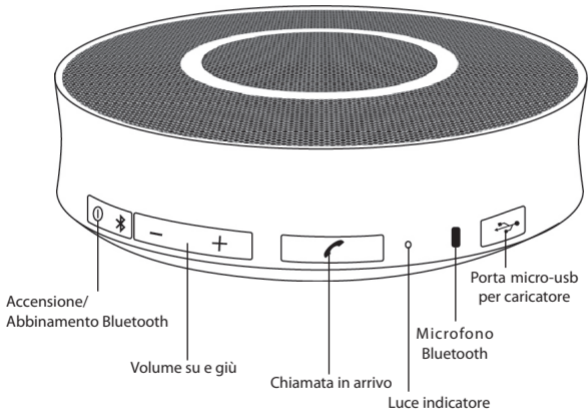

La qualità principale di **neo2go** è il design acustico brevettato, che sfrutta una dimensione più piccola per una migliore resa audio

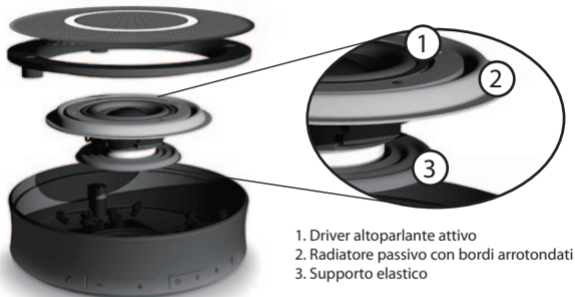

Bluetooth V2.1 + EDR(A2P)

Massima Distanza Cordless: 10 metri

Autonomia: fino a 12 ore (batteria litio 1000mAh)

Alimentazione: 2.0W T.H.D. <1%

Dimensioni $\varnothing 100 \times 32H$ (mm): 132g





neo2go altoparlante wireless resistente all'acqua

neo2go è progettato per migliorare l'esperienza degli utilizzatori di smart phone.

Sul mercato ci sono oltre 100 milioni di smart phone con il Bluetooth e **neo2go** è progettato per questi clienti potenziali per ascoltare musica di qualità quasi ovunque senza cuffie.



Collegatevi con lo SmartPhone e altri dispositivi Bluetooth

1. Accendete **neo2go**   il LED è di colore blu, poi lampeggerà blu e rosso durante la ricerca
2. Il Bluetooth effettuerà la ricerca automatica degli ultimi dispositivi abbinati (fino a 10 secondi).
3. Effettuato l'abbinamento, il tasto LED frontale continuerà a lampeggiare (luce blu).
4. Se il Bluetooth non trova gli ultimi dispositivi abbinati, cercherà nuovi dispositivi cui abbinarsi.
5. Avviate il vostro dispositivo Bluetooth e cercate **neo2go**. Il vostro Bluetooth manager identificherà l'ID Bluetooth "**neo2go**". Una volta identificato, selezionare per effettuare l'abbinamento ed il collegamento con **neo2go**.
6. Se il Bluetooth non riesce ad effettuare l'abbinamento (circa 2 minuti e mezzo), si spegnerà automaticamente. Seguite le istruzioni del vostro dispositivo per l'abbinamento Bluetooth. (variano a seconda dei modelli!) Il codice iniziale di abbinamento è 0000. Alcuni dispositivi impiegano pochi secondi per effettuare l'abbinamento, altri possono impiegare più tempo.
7. **neo2go** può abbinarsi a due dispositivi Bluetooth contemporaneamente. Quando collegate la prima unità, premete il tasto (alimentazione)   di abbinamento fino a quando l'indicatore LED lampeggia blu e rosso, poi il vostro secondo dispositivo Bluetooth può rilevare nuovamente neo2go. Ripetete il punto 5.

Godetevi la musica in modalità wireless.



Regolate audio e volume.

Regolate il volume   al livello desiderato. Il bip indicherà il livello massimo raggiunto.

neo2go altoparlante wireless resistente all'acqua

Spegnimento: premete e tenete premuto il tasto alimentazione/abbinamento fino allo spegnimento del LED. (circa 5 secondi)
l'altoparlante si spegnerà automaticamente dopo 10 minuti se non viene collegata a nessun dispositivo.

Funzione chiamata

1. accettare o terminare una chiamata: 
premere il tasto Telefono <1.5 secondi per accettare o terminare una chiamata
2. rifiutare una chiamata in arrivo 
premete e tenete premuto il tasto Telefono >1.5 secondi.

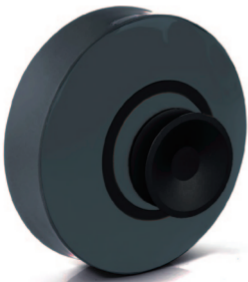

La ventosa double-face è l'elemento più interessante di **neo2go**. Grazie al suo design intelligente, l'altoparlante può essere fissato a qualsiasi superficie liscia (piastrelle, specchi, finestre, etc.)